

LECTURE NOTE
ON
MANUFACTURING TECHNOLOGY

DIPLOMA 5TH SEM



DEPARTMENT OF MECHANICAL ENGINEERING

PREPARED BY:ER.MONALIN MOHANTY

**GANESH INSTITUTE OF ENGINEERING AND TECHNOLOGY
(POLYTECHNIC)**

(Approved by AICTE)

ANDHARUA,BHUBANESWAR

OBJECTIVES:

Students will develop an ability towards

- Comprehending required material properties for cutting tools
- Comprehending machining mechanism principle and factors affecting machining performance
-

Comprehending working principle and components in machining tools including lathe, milling, shaping, planning, slotting machines

- Comprehending requirement of surface finish and realize principles involved in grinding and superfinishing operations

1.0 Tool Materials

1.1 Composition of various tool materials

1.2 Physical properties & uses of such tool materials.

2.0 Cutting Tools

2.1

Cutting action of various tools such as Chisel, hacksaw blade, dies and reamer

2.3

Turning tool geometry and purpose of tool angle

2.5

Machining process parameters (Speed, feed and depth of cut)

2.6

Coolants and lubricants in machining and purpose

3.0. Lathe Machine

3.1

Construction and working of lathe and CNC lathe

- Major components of a lathe and their function
- Operations carried out in a lathe (Turning, thread cutting, taper turning, internal machining, parting off, facing, knurling)
- Safety measures during machining

3.2 Capstan lathe

- Difference with respect to engine lathe

- Major components and their function

- Define multiple tool holders

3.3 Turret Lathe

- Difference with respect to capstan lathe

- Major components and their function

3.4 Draw the tooling layout for preparation of a hexagonal bolt & bush

4.0 Shaper

4.1 Potential application areas of a shaper machine

4.2 Major components and their function

4.3 Explain the automatic feed mechanism

4.4 Explain the construction & working of tool head

4.5 Explain the quick return mechanism through sketch

4.6 State the specification of a shaping machine.

5.0 Planning Machine

5.1 Application area of a planer and its difference with respect to shaper

5.2 Major components and their functions

5.3 The table drive mechanism

5.4 Working of tool and tool support

5.5 Clamping of work through sketch.

6.0 Milling Machine

6.1 Types of milling machine and operations performed by them and also same for CNC milling machine

6.2

Explain work holding attachment

6.3

Construction & working of simple dividing head, universal dividing head

6.4

Procedure of simple and compound indexing

6.5

Illustration of different indexing methods

7.0. Slotter

7.1 Major components and their function

7.2 Construction and working of slotter machine

7.3 Tools used in slotter

8.0 Grinding

8.1 Significance of grinding operations

8.2 Manufacturing of grinding wheels

8.3 Criteria for selecting of grinding wheels

8.4 Specification of grinding wheels with example Working of

Cylindrical Grinder

Surface Grinder

Centreless Grinder

7

9.0 Internal Machining operations

Classification of drilling machines

9.1 Working of

Bench drilling machine

Pillar drilling machine

Radial drilling machine

9.2 Boring

Basic Principle of Boring

Different between Boring and drilling

9.3 Broaching

Types of Broaching (pull type, push type)

Advantages of Broaching and applications

10 Surface finish, lapping

10.1 Definition of Surface finish

10.2 Description of lapping & explain their specific cutting.

There are many types of cutting process done in different condition. In such condition along with the general requirement of the cutting tools, they need some unique properties. To achieve these properties the cutting tools are made up of different materials. The material chosen for a particular application depends on the material to be machined, type of machining, quantity & quality of prodⁿ etc.

According to the material the tools are classified into

1. Carbon tool steel
2. High speed steel (HSS)
3. Cymantite carbide
4. Ceramics tools
5. Cubic boron nitride tool (CBN)
6. Diamond tool

1. Carbon tool steel:-

→ Its temperature range from 250°C .
→ It is one of the inexpensive metal cutting tool used for the low-speed machining operation.

→ This carbon steel cutting tool have the composition 0.6 - 1.5% Carbon & very small amount of (less than 0.5%) Mn & Si.

→ High carbon steel have the ability to maintain sharp cutting edge & it possess good machinability.

→ It doesn't perform in a modern & machining operation.

→ Carbon tool steel used in twist drill, milling tool, turning use on shock material such as brass, Al, Mg etc.

2. High Speed Steel:-

→ This is a high carbon steel with a significant amount of alloying elements such as tungsten, Mo, Cr etc. to improve hardenability, toughness & wear resistance.

→ It gives a higher metal removal rate & it loses its hardness at a moderate temperature about 650°C , therefore a coolant should be used to increase tool life.

→ It can be used many times by resharpenering some surface & treatment is done on the HSS to improve its properties.

Surface treatment used in HSS:-

Superfinishing - reduce friction

Nitriding - increase wear resistant

Chromium electro plating - reduce friction

Oxidation - reduce friction

→ It is used in drill, mining, milling cutter, single point lathe tool.

T type - Tungsten predominant type

M type - Mo predominant type

3. Cementite carbide tool:-

→ It is produced by powder metallurgy technique.

→ It consists of Tungsten, tantalum & Titanium Carbide with cobalt as a binder (when the binder is Ni & Mo then it is called Cermat)

→ Cementite carbide tool are extremely hard, they can withstand very high speed cutting operation.

→ It doesn't lose their hardness upto 1000°C .

→ A high cobalt tool is used for a rough cut while low cobalt is used for finishing operation.

4. Ceramics:-

1. Ceramic:-

→ The most common ceramic materials are alumina oxide (Al_2O_3) & Silicon nitride. Powder of ceramic material compacted in insert shape, then sintered at high temperature.

→ Ceramic tools are chemically inert & possess resistance to corrosion.

→ They have high compressive strength. they are stable upto temperature 1800°C .

→ they are 10 times faster than HSS.

→ The friction betⁿ tool face & chip are very low & possess low heat conductivity, usually no coolant is required, they provide a very excellent surface finish.

5. CBN's

- It is the second hardest material after diamond.
- They are generally used in hand machine.
- They offer high resistance to abrasion & wear as an abrasive in grinding wheels.
- Sharp edges are not recommended.

6. Diamond's

- It is the hardest material & it is also expensive.
- It poses a very high thermal conductivity & M.P.
- The diamond offers an excellent abrasion resistance, low friction coefficient & low thermal expansion.
- It is used in machining very hard material such as Carbides, nitrides, glass etc.
- Diamond tools give a good surface finish & dimensional accuracy.
- They are not recommended for machining steel.

→ Cutting tool materials are the materials used to make cutting tools which are used in machining. (drill bits, tool bits, mining cutters etc.) but not other cutting tools like knives & punches.

→ Cutting tool materials must be harder than the material of work piece, even at high temperature during the process.

→ The following properties required for cutting tool

1. Hardness, hot hardness & pressure resistance.
2. Bending strength & toughness.

iii. Inner bonding strength

iv. Wear resistance

a. edge resistance

b. edge strength

c. small propensity for diffusion & adhesion.

There is no material that shows all of the properties at the same time.

Tool material	Cutting speed	Temperature (max)	Hardness
Carbon tool steel		450°C	up to HRC 65
HSS (30-50 m/min cutting range)	30-50 m/min	650°C	up to HRC 64 30-50 m/min
Cementite Carbide	60-200 m/min	1000°C	up to HRC 90
Ceramic	300-600 m/min	1200°C	up to 93 HRC 90.3
CBM	600-800 m/min	—	45 up to HRC 95
Diamond		600°C	

HRC - High Sphering Capacity

Chapter - 2 :- Cutting Tools :-

Cutting action of various tools :-

1. Chisel :-

A chisel is a tool with a characteristically shaped cutting edges (such that wood chisel have part of their name to a particular grind) of blade on its end, for carving or cutting hard material such as wood, stone or metal by hand, struck with a mallet or mechanical power. The handle & blade of some types of chisels are metal or wood with a sharp edge with it.

Cutting angle of chisel :-

The angle which is usually set to 25° is called grinding angle as the chisel ground down to this angle when bit made. The second angle (usually 30°) is called a cutting angle & allows for re-sharpening of the chisel itself.

2. Hacksaw :-

A hacksaw is a fine tool to saw originally & mainly made for cutting metal. (The equivalent saw for cutting wood is usually saw law) most hacksaw are hand saw with a 'c' clamp frame that holds a blade under tension, such hacksaw have a handle usually a piston grip, with pin for attaching narrow disposable blade. The frame may also be adjustable to accommodate blade of different size. A letter on

other mechanism is used to put the thin blade under tension.)

on hacksaw, as its most frame such as the blade can be mounted with the teeth facing toward or away from the handle resulting in cutting action on either push or pull stroke. (As normal use cutting vertically downwards which works held in bench vice, hacksaw blade are set to be facing forward)

3. Dies :-

→ Cutting die used to cut the metal to utilize the cutting or shearing action.

→ The common dies are notching, trimming, shaving, blanking etc.

→ Die cutting is typically refers the cutting action of a die cross.

→ Die cutting tooling is fundamentally a comb of steel blade & rubber prepared into a specific state & structure to enable compression of lubricated material hence having a specific shape.

Different types of dies using in sheet metal :-

Compound die, multiple die

Comb die, progressive die,

What does a die do? :-

A die is used to cut or form the male portion of the mating pair (A nut & A bolt). The process of cutting or forming thread using a tap is called tapping whereas the process using a die is called thread rolling.

How does a die work?

- Tapping is when threads are cut into a cylinder (bolt).
 - To use a tap or a die, first determine the no. of threads per inch (TPI) of the part to be fixed.
 - A gauge system that has a no. of different pins is to be used to calculate the TPI of the bolt or nut.
- Advantage :-

Die cutting yields a level of uniformity of a final product i.e. almost unmatched.

Die

4. Reamer :-

- The main cutting action of reamer is done by shearing taper, the sizing action is to guide the reamer & also smooth or size the hole.
 - The back taper reduces friction between reamer & hole surface.
- Function :-
- A reamer is a type of rotary cutting tool used in metal working precision reamers.
 - Reamers are design to a large size ^{of hole than} ~~is~~ previously ~~to~~ turn hole by small amount but a high degree of tolerance.

Why are reaming operation performed :-

- Reaming performed using same type of machine like drilling.
- Reamer is a rotary cutting tool with one or more cutting elements use bar & varying size to control the previously hole.
- It's principle support ~~is~~ during cutting action of the work piece.

Reamers & it's types :-

- I. Hand reamer
- II. Machine reamer
- III. Chucking reamer
- IV. Fluting reamer
- V. expandable reamer
- VI. Taper reamer
- VII. adjustable reamer

What is tool geometry :-

- Geometry of a cutting tool ^{are} the shape & angle by which the cutting portion of a cutting tool are ground.
 - It influence ~~are~~ the type of machining process, the material, the efficiency & economy, the quality of the finished part, & the life of ^{the} cutting tool.
- What is Tool angle :-
- The angle included between the top & front faces of the tool on an angle used to designate the form of a cutting edge of a tool.

Tool geometry of turning tools:-

→ Both material & geometry of the cutting tool play very important role on their performance in achieving effectiveness, efficiency and overall economy of machining.

→ Cutting tools may be classified according to the no. of major cutting edges (points) involve as follows.

i. Single point tool

Ex: turning tools, shaping, planing & slitting

ii. Boring tool.

iii. Double point

Ex: Drill

iv. Multipoint (more than two)

Ex: milling cutter, broaching etc.

Concept of rake angle of cutting tools:-

→ Rake angle is provided for each of chip-throw & overall machining.

→ Rake angle may be positive or negative or even zero.

Concept of clearance angles of cutting tools:-

→ Clearance angle is essentially provided to avoid rubbing of the tool with the machine surface which cause loss of energy & damage of both the tool & the job surface.

→ Hence the clearance angle is a must & must be positive (3° to 15°) depending upon the tool work material

& type of machining operations like turning, drilling, boring etc.

Terminology of single point cutting tool is

Back

Back rake angle

→ It viewed the side facing from the end of the work piece it is the angle form by the base of the tool & line parallel to the floor.

→ A positive back rake angle flip the tool base back, a negative back rake angles flip it forward & up.

End cutting edge angle:-

→ It viewed a from above looking down at the cutting tool, it is the angle formed by the end flank of the tool & the line parallel to the work piece centerline.

End relieve angle:-

It viewed from the side facing the end of the work piece, it is the angle formed by the end flank of the tool & a vertical line down to the floor.

Face:-

The flat surface of a single point tool into which the work piece rotates during a turning

operations.

Flank:-

A flat surface at a single point tool i.e. adjacent to the base of the tool. During turning the side flank faces the direction that the tool is fed into the workpiece & the flank passes over the newly machined surface.

Lead angle:-

→ A common name for the side cutting edge angle of a tool holder is built with dimension that skip the angle of an insert, the lead angle takes this change into consideration.

Side rake angle:-

It is the angle formed by the face of the tool & the centre line of the work piece.

Side relief angle:-

It is the angle formed by the side flank of the tool & a vertical line down to the flank.

Note radius:-

→ The rounded tip of the cutting edge of a single point tool.

→ The greater the nose radius, the greater the roundedness of the tip.

→ A zero degree nose radius creates a sharp point

Side cutting edge angle:-

It is the angle formed by the side flank of the tool & a line perpendicular to the work piece centerline.

Process parameter:-

→ For any machining or metal cutting operation three relative motion betⁿ the work piece & the cutting tool are necessary for gradual removal of materials from work piece. In fact, the simultaneous action of all three relative motion causes advancement of cutting tool towards work material along the path generating a finish surface with the shape, size & tolerance.

→ These three relative motion are called cutting parameters.

→ The process parameter in machining all those parameter that inherent to a any machining operation & should have a suitable finite value to smooth & efficient removal of material. Each parameter directly effect machining operation.

→ In machining three parameters are

1. Cutting speed or cutting velocity
2. feed rate
3. depth of cut

1. Cutting velocity (V_c)

→ It is the most important cutting parameter that provide necessary cutting motion. In case of either rotating tool such as milling, drilling & grinding etc. or rotating workpiece such as turning, the peripheral vel. of cutter or workpiece is considered as cutting velocity. The rotational speed is called cutting speed whereas the tangential velocity is called cutting velocity.

→ It is denoted by V_c .

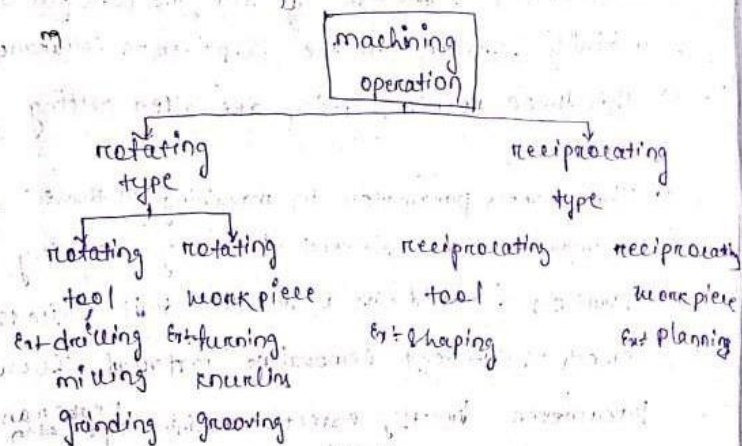

2. Feed rate (f)

→ The auxiliary cutting motion is provided by the feed rate or feed velocity.
 → usually the dirⁿ of feed velocity is perpendicular to that of the cutting velocity. The primary objective

of feed velocity is to advance cutter w.r.t the workpiece to remove material from a wider surface.

→ Basically it helps in covering the entire surface of the workpiece by moving either cutting tool or workpiece.

3. Depth of cut (t)

→ The tertiary cutting motion that provides necessary depth cut in work material i.e. intended to remove by machining.

→ It is given in the third & perpendicular dirⁿ of the simultaneous action of three cutting parameters result in removal of excess material from workpiece.

Features or process parameters:-

It must be,

- a primary factor i.e. it should not be any other factor that control it.
- It must be supplied during machining.
- It should have a finite value.
- It should directly effect machining performance.
- It can be varied externally without changing the work tool combination.

Process parameter different from influencing parameters:-

→ Influencing parameters include all those parameters that can directly or indirectly influence the machining operations thus all process parameters are influencing parameters apart from velocity, feed & depth of cut, there are many other parameters that can influence performance considerably, however they are not inherent to machining process.

→ A list of such parameters relevant to conventional machining

- i. Cutting environment
- ii. Tool geometry including nose radius.
- iii. work material
- iv. Tool material.
- v. Tool coating
- vi. Work and tool setting.

Coolant and lubricant in machining

The basic purpose of coolant is to take away generated cutting heat from cutting zone; and thereby keep the cutting zone temp. low. The basic purpose of lubricant is to reduce co-efficient of friction betⁿ rake surface of cutting chip and thereby minimize heat generation.

3. Straight oil (petroleum or vegetable oil)

A. Synthetic fluids

S. Semi synthetic fluids.

→ What are the three main properties of coolant?

- i. Prevent freezing & boiling
- ii. Lubricates the water pump seal.
- iii. Inhibits corrosion.

What are the different type of lubricants?

→ There are 3 different type of lubrications.

1. boundary
2. mixed
3. full film

→ Each type is different but they all rely on a lubricant and the additive with in the oil to protect against to wear.

→ Full film lubrication can be broken down into two forms

- i. Hydro dynamic
- ii. Elasto hydrodynamic

What are some examples of lubricants?

→ Lubricants include battery alcohol, casters & wax etc.

→ External of lubricants provides metal release & help to reduce temperature.

→ The common example of external lubricants

- i. Paraffin
- ii. metal soap.
- iii. Amide
- iv. Fatty acid.

Each coolant a lubricant?

→ Cutting fluid is a coolant that also serves as a lubricant for metal shaping machine tools.

→ Oils are often used for application where water is unsuitable.

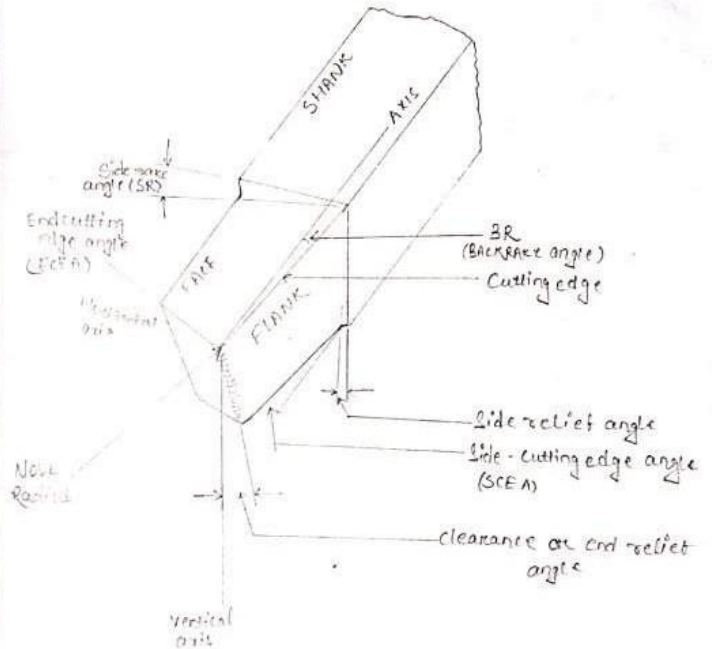

- BR - i) Back rake angle
- SR - ii) Side rake angle
- SR - i) End relief angle (clearance) ER or BR
- SR - ii) Side relief angle " " " "
- CE - i) End cutting edge angle (CEA)
- CS - ii) Side cutting edge angle (SCEA)

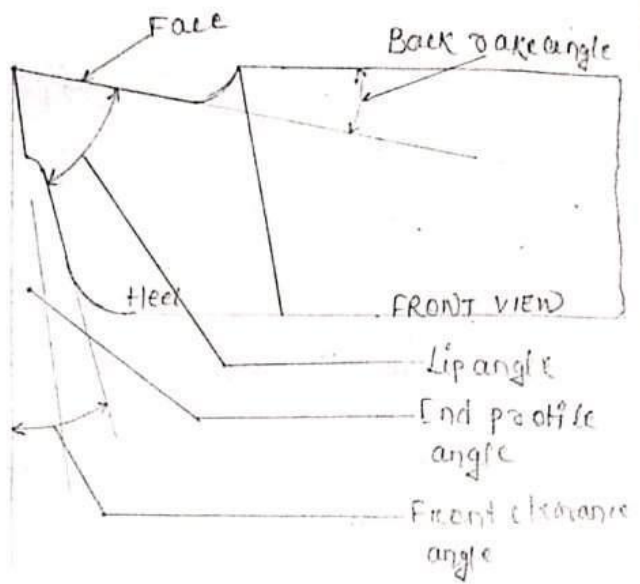
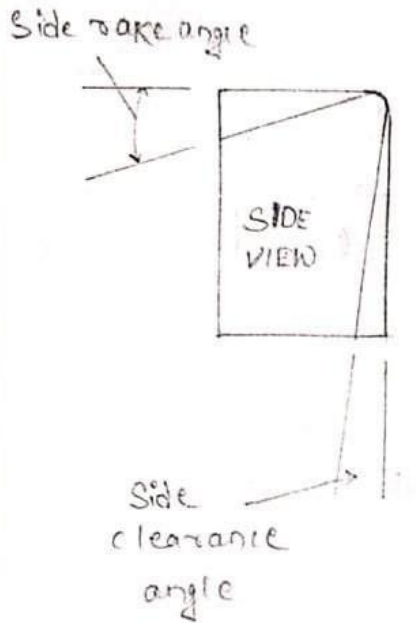
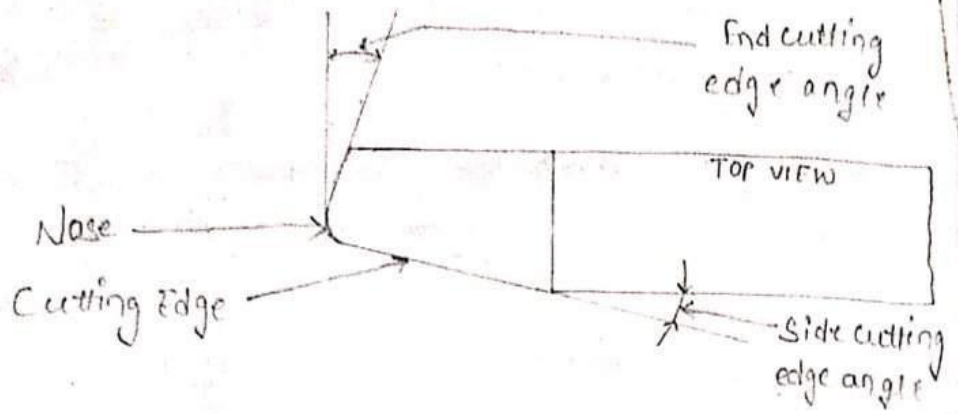

Construction & working of lathe & CNC lathe.

Definition of lathe machine :-

- A machine tool that is used to remove unwanted metals from the work piece to give the desired shape and size is called 'lathe machine'.
- It is also called as centre lathe because of two centres b/w which the job can be held & rotated.

Functions of lathe :-

- Main function of lathe is to remove excess materials in the form of chips by rotating the workpiece against a stationary cutting tool.
- To cut the material properly the tool should be harder than the material of the work piece.

Main parts of lathe machine :-

1. Bed :-

- It is the base of the lathe machine made up of single piece casting of semi steel (chilled cast iron).
- The bed consists of two heavy metal slides running length wise with 'V' turned on them and rigidly supported with cross girders.

functions :-

- It is sufficiently rigid and good damping capacity to absorb vibration.
- It prevents the deflection produced by the cutting forces.
- It supports the headstock, tailstock, carriage and other components of the lathe machine.

2. Head stock :-

Head stock is situated at the left side of the lathe bed and it is the house of the driving mechanism and electrical mechanism of a lathe machine tool.

functions :-

- It holds the job on its spindle nose having external screw threads and internally Morse taper for holding the lathe center and it is rotating at a different speed by cone pulley or all geared drive. There is a hole through out the spindle nose handling long bar work.
- Head stock transmits power from the spindle to the bed rod, lead screw & thread cutting mechanism.

Accessories mounted on headstock spindle :-

- Three jaw chuck
- Four jaw chuck
- Lathe center & lathe dog
- Collet chuck
- Face plate
- Magnetic chuck

Note :-

- A separate speed change gearbox is placed below headstock to reduce the speed in order to have different bed rates for threading & automatic lateral movement of the carriage.
- The bed rod is used for most turning operation and the lead screw is used for thread cutting operation.

2020/4/3 23:28

3. Tail Stock

Tail stock is situated on the right side above the lathe bed

Functions:-

- Support the long end of the job by holding & minimize its sagging.
- It holds the tool bar performing different operations like drilling, reaming, tapping etc.
- Used for a small amount of taper on a long job by offsetting the tail stock.

4. Carriage

→ It is located b/w headstock & tail stock on the lathe bed guide ways.

→ It is used to support, guide & feed the tool against the job when the machining is done.

Functions:-

- It holds, moves & control the cutting tool.
- It gives rigid supports to the tool during operations.
- It transfers power from feed rod to cutting tool through apron mechanism for longitudinal cross feeding.
- It simplifies the thread cutting operation with the help of lead screw & half nut mechanism.

It consists of

- Laddle
- Cross-slide
- Compound rest
- Tool post
- Apron
- Compound slide

It provides three movements to the tool

- Longitudinal feed - through carriage movement
- Cross feed - through cross slide movement
- Angular feed - through top slide movement

(i) Laddle:-

- It is 'L' shaped casting
- It connects the pair of bed guide ways as a bridge.
- It sits over the bed and slides along the bed b/w head stock & tail stock.

(ii) Cross slide:-

- It is assembled on the top of the laddle.
- The top surface of the cross slide is provided with T-slot.
- The cross slide hand wheel is graduate on its rim to enable to give known amount of feed as accurate as 0.05 mm.

(iii) Compound Rest:-

- It is a part which connects cross slide and compound slide.
- It is mounted on the cross slide by tongue and groove joint.

Functions:-

- It supports the tool post and cutting tool in various position.
- It is necessary for turning angles and bearing short tapers.

(iv) Tool post:-

- It is the topmost portion of the carriage and it is used to hold various cutting tools on tool holder.

Types :-

- Single way / cross tool post
- Four way tool post
- Quick change tool post
- British type tool post.

(V) Apron :-

- It is the house of the feed mechanism.
- It is bolted to the saddle & hangs over in front of the bed.

(VI) Compound slide :-

- It is a T-shaped rounded flat, which is fixed with cross slide upper surface by two bolts, which is related to a micrometer sleeve & screw handle with the outer edge of screw.
- This slide is only used for long job taper turning.
- Automatic feed is not possible in compound slide.

5. Main Spindle :-

- It is a hollow cylindrical shaft in which long jobs can pass through.
- Its base has a standard Morse taper.
- It is used for holding the live centers.
- The spindle rotates on two large bearings housed on the head stock casting.

6. Lead screw :-

- It is used to transmit power to carriage through gear and clutch arrangement in the carriage apron.
- It converts rotational motion into linear motion.
- It is used for thread cutting operation.

7. Live Center :-

- It is mounted on bearings and rotates with the work.
- It is used to hold or support a work piece.

8. Dead center :-

- It is used to support the work piece at either the fixed or rotating end of machine.

Functions :-

Dead centers are typically fully hardened to prevent damage to the important mating surfaces of the taper and to preserve the 60° angle of the nose.

9. Feed rod :-

funⁿ :- It is used to move the carriage from the left side to the right side and also from the right side to the left side.

10. Chuck :-

funⁿ :- It is used to hold the work piece securely.

Types :-

- 3 jaw self centering chuck
- 1 jaw independent chuck

11. Leg :-

- funⁿ :- Leg carry the entire load of a lathe machine tool and transfer to the ground.
- The legs are firmly secured to the base by the foundation bolt.

Working principle of Lathe Machine

Working Principle :-

- The lathe is a machine tool which holds the workpiece b/w two rigid and strong supports called centers or in a chuck on base plate which revolves. The cutting tool is rigidly held and supported in a tool post which is fed against the revolving work.
- When the cutting tool is fed parallel to the workpiece a cylindrical surface is formed.
- When the cutting tool is fed at an angle relative to the axis of the workpiece, it produces a tapered surface and also called as taper turning.



Lathe operation :-

The engine lathe is an accurate & versatile machine on which many operations can be performed, which are as follows.

① Plain turning & step turning :-

Plain turning :-

It is the operation of removing excess amount of material from the surface of a cylindrical job.

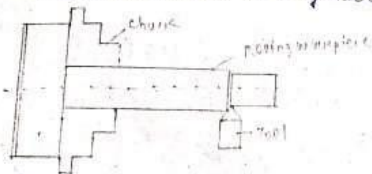

Step turning :-

It produces various steps or different diameters.

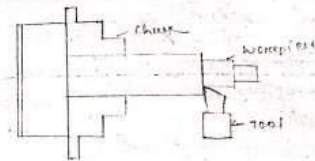

② Facing :-

It is a machining operation by which the end surface of the workpiece is made flat by removing metal from it.

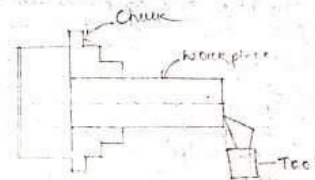

③ Parting :-

Parting or cutting off is the operation of cutting away a divided length of the workpiece i.e.

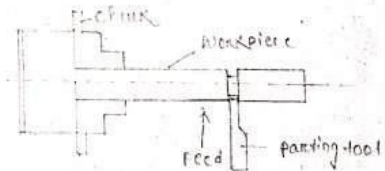

④ Drilling :-

Drilling is the operation of producing a cylindrical hole in the work piece.

2020/4/3 23:29

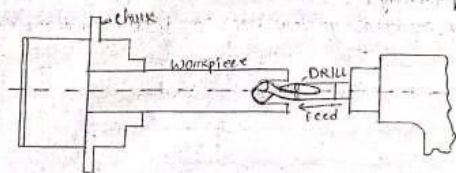

⑤ Reaming :-

The holes that are produced by drilling are rarely straight & cylindrical in form. The reaming operation finishes & sizes the hole already drilled into the workpiece.

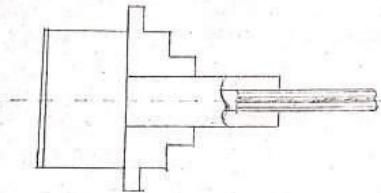

⑥ Boring :-

It is the process of enlarging a hole already produced by drilling.

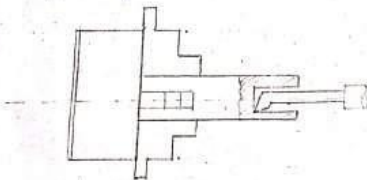

⑦ Knurling :-

→ It is a process of impressing a diamond-shaped or straight line pattern into the surface of workpiece.
 → It is essentially a roughening of the surface and is done to provide a better gripping surface.

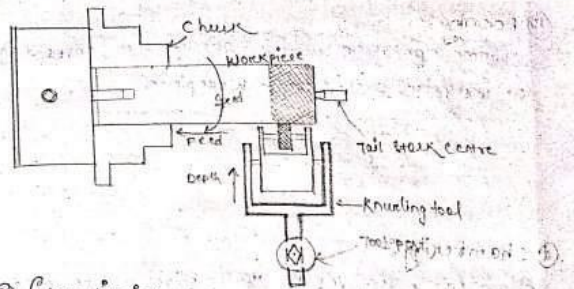

⑧ Grooving :-

It is the operation of making grooves of reduced diameter in the workpiece.

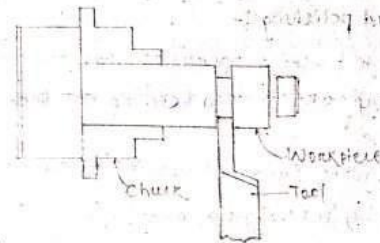

⑨ Threading :-

It is the operation of cutting of the required form of threads on the internal & external cylindrical surfaces.

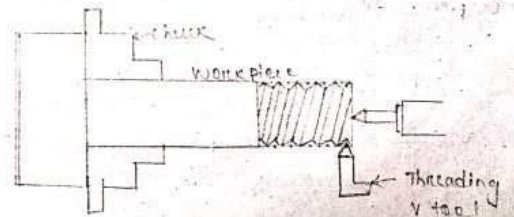

2020/4/3 23:29

⑩ Forming :-

It is an operation, which produces a convex, concave or irregular profile on the workpiece.

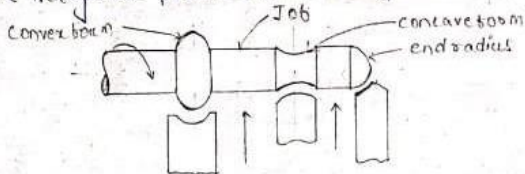

⑪ Chamfering :-

- Chamfering removes the sharp edges and rough edges and makes the handling ease.
- Chamfering can be done by a form tool having angle equal to chamfer which is generally kept at 45° .

⑫ Filing and polishing :-

- Filing is the finishing operation that removes rough edges, sharp corners and feed marks from the workpiece.
- After filing, the surface quality of the workpiece is improved by polishing operation.

⑬ Taper turning :-

It is the operation of producing a conical surface by gradual reduction in the diameter of a cylindrical workpiece.

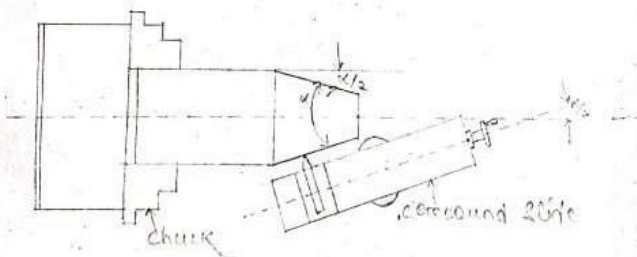

Safety measures during machining :-

→ ① Always stop the lathe before making adjustment.

② Do not

- Do not change spindle speeds until the lathe comes to a complete stop.
- Always wear protective eye protection.
- Never lay tools directly on the lathe ways. If a separate table is not available, use a wide board with a cleat on each side to lay on the ways.
- Use two hands when standing the workpiece. Do not wrap the sand paper or emery cloth around the workpiece.
- Remove rings and watches.
- Keep the floor free from obstructions or slip hazards.
- Follow job specification for the speed, feed & depth cut for materials being turned. Make sure all work runs true and centered.
- Stop lathe before taking measurements of any kind.
- Keep working surface clean of scraps, tools & material.

Types of lathe machine :-

① Center (or) engine lathe :-

- It is the most widely used lathe machine.
- Part :- Bed, saddle, headstock & tailstock etc.
- The headstock of an engine lathe is rigid & tailstock is movable which is therefore used for knurling.
- function :- It feeds the cutting tool in both directions, i.e. longitudinal and lateral direction with the help of feed mechanism.

mechanism:-

Driven by gear mechanism or pulley mechanism.

Types of driven mechanism

- ① Belt driven
- ② Motor driven
- ③ Gear head type.

Turret lathe:-

It is a lathe form of metal working lathe i.e. used repetitive prodⁿ or duplicate parts which by the nature of their cutting process usually interchangeable.

Capstan lathe:-

A Capstan lathe is a processing machine used to make the same parts again & again. The cutting bits are mounted on a rotatable turret known as capstan, which permits the client to rapidly change the intro of the bits for being without needing to take off the first bit & attach a new one.

What is Capstan lathe used for?

→ A capstan or turret lathe is used to manufacture any no. of identical pieces in the minimum time.

→ These lathes are first developed in USA in 1960.

→ Capstan lathe is one of the type of semi automatic lathe.

What is turret lathe

1. Ram type

2. Saddle type.

1. Ram type:-

In the ram type turret lathe a slide or ram carrying the turret moves back & forth on a saddle which is clamp to the machine bed.

2. Saddle type:-

In this type the hexagonal turret is rigidly mounted on saddle & the whole unit moves

back & forth on the bed ways.

What is swing of a lathe?

The swing of a lathe machine is actually the dimensions that measures the max. diameter of the workpiece that a lathe is able to rotate without heating the bed.

Diff. betⁿ capstan & turret lathe

Capstan	Turret
→ It is a light weight machine	→ It is a heavy weight machine
→ In capstan lathe the turret tool head is mounted over the ram & i.e. mounted over the saddle.	→ In turreted tool head is mounted over the saddle like a single unit.
→ For providing feed to the tool ram is moved.	→ For providing feed to the tool the saddle is moved.
→ Capt ⁿ because of no saddle displacement the moment of turret tool head over the longitudinal dir ⁿ of bed is small along with the ram.	→ Turret tool head moves along with the saddle over the entire bed in longitudinal dir ⁿ .
→ Use for center workpiece bcz of limited ram movement.	→ Use for longer workpiece bcz of saddle movement on the bed.
→ It's working operation are fast bcz of lighter in construction.	→ It's working operation are slower bcz of heavier in construction.
→ Heavy cuts on the workpiece can't be given bcz of non rigid construction.	→ Heavy cuts on the workpiece is given bcz of rigid construction.

→ For indexing turret tool head of the ram is reverse & turret tool index automatically

→ The turret head can't be moved in the lateral dirⁿ of the bed.

→ In capstan lathe correct is used to grip the job.

→ Use for machining work piece upto 60mm diameter.

→ These are usually horizontal lathe.

→ For indexing - turret tool head the turret is rotated manually after releasing the clamping lever.

→ The turreted head can be moved crosswise i.e. the lateral dirⁿ of bed.

→ In turret lathe power jaw chuck is used to grip the job.

→ Use for machining work piece upto 120mm diameter.

→ Turret lathe are available in horizontal & vertical.

Engine lathe

→ An engine lathe is a type of machinery, set horizontally & it is often to use cut metal.

→ The metal is turned the machine uses special cutting tool to create the desired shape. Because of the lathe, it can create various specific forms & commonly used to spin sheet metal.

Difference betⁿ turret lathe & engine lathe.

Turret lathe are planed to act as production machine & engine lathe is planed machine various type of job within limits. i.e one time setting is over you mustn't change the tool.

~~Diff bet turret~~

what is precision lathe?

Precision lathe are also known as standard manufacturing lathe & is used for all lathe operation such as turning, taper turning, knurling, reaming etc and can be adapted for special milling operation with the appropriate fixture

2020/4/3 23:30

Shaping machine or shaper

- A shaping machine or shaper is used to generate flat (plane) surfaces by means of a single point tool similar to a lathe tool.
- A shaping machine is a reciprocating type of machine tool in which the ram moves the cutting tool backward & forward in a straight line.

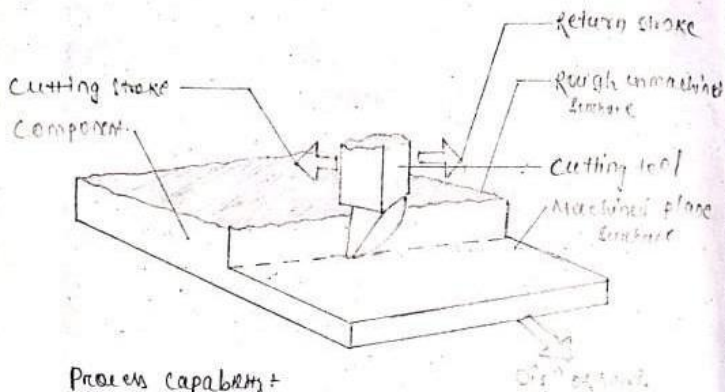

Process capabilities

- Shaping process involves short setup time & uses relatively inexpensive tools.
- Shaping is often used for emergency production of gears, racks etc.
- It is often possible to produce one ^{upto} such part in a shaper in less time than is required nearly to setup for production on other, alternative equipment with a higher output rate.
- However metal removal by shaping may be as much as 5 times that for removal by milling or grinding.

Working principle

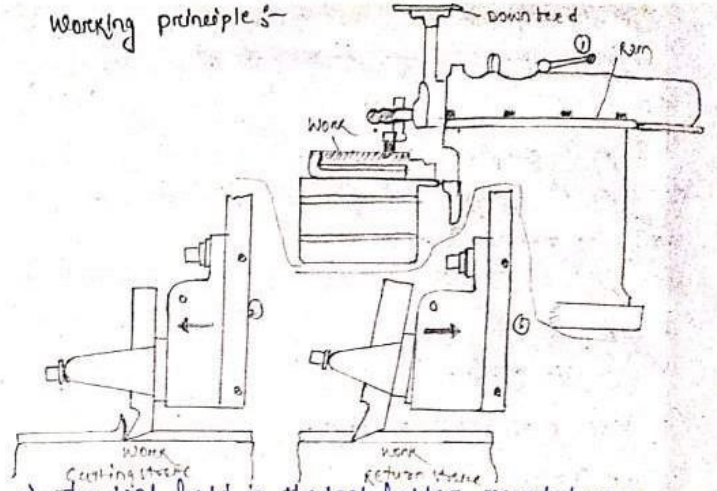

- The tool held in the tool holder mounted on the ram moves forward & backward in a straight line over the workpiece rigidly held in a vice clamped over the work table.
- Each time the tool moves forward, it cuts the metal from workpiece. Each time the tool moves backward the tool leaves clear of the workpiece.
- The work remains stationary during the forward (cutting stroke of the tool) but moves across by one cross transverse during the return (non cutting stroke).
- That the appearance of the machine surface is of a succession succession of closely straight line wave.

Types of

2020/4/3 23:30

Types of shaper :-

Shaper may be classified on the basis of

a) Design of worktable as

1. Standard shaper

2. Universal shaper

b) Driving mechanism as

1. Crank shaper

2. Gear shaper

3. Hydraulic shaper

c) Direction of travel of ram

1. Horizontal

2. Vertical

3. Travelling hand shaper

d) Nature of cutting stroke as

1. Push cut shaper

2. Draw cut shaper

Parts of a shaper machine :-

1. Base :-

→ The base of shaper supports the column or pillar which supports all the working parts such as ram, worktable, drive mechanism etc

→ Base is a heavy C.I body.

2. Column, pillar or body :-

→ The shaper has a column which is ribbed casting of cellular construction.

→ The top of the column carries the ram sideways, the table sideways are machined on the front of the casting.

→ The crank & the slotted link mechanism that drives the ram is contained within the column.

→ The driving motor, the variable speed gear box, lever & other control of the shaper are also contained in the column.

3. Cross rail :-

→ The cross rail carries the horizontal table sideways & is mounted on the vertical guideways of the column.

→ The cross rail can be raised or lowered by means of an elevating screw in order to compensate for dirt between of work.

→ The cross rail is a heavy casting & it also carries the table cross feed screw together with the pawl & ratchet intermittent drive mechanism.

4. Saddle :-

→ Saddle is ribbed to the cross rail & supports the table. If the table is removed the work can be bolted or clamped to the T-slot in front of the saddle.

→ Crosswise movement of the saddle causes the worktable to move sideways.

5. Table :-

→ The worktable is a box shaped casting with T-slots in its upper surface & down one side. It also has a vee machined in the vertical side to carries cylindrical work.

→ The upper surface of the worktable is machined after assembly to ensure that the working surface of the table is a true datum for work setting.

→ The worktable is bolted to the saddle & can move vertically & crosswise with the help of saddle & cross rail.

6. Ram's

→ Ram is rigidly braced casting & is located on the top of the column.

→ The ram is driven back & forth in its slide by the slotted link mechanism.

→ The ram contains a stroke positioning mechanism & the down feed mechanism.

7. Tool head's

→ Tool head slides in a dovetail as the front of the ram by means of T bolts.

→ It can swivel from 0° to 90° in a vertical plane.

→ The tool head can be raised or lower by hand feed bar vertical cut on the workpiece.

→ The tool head holds the tool. The tool head ^{important} ~~impact~~ the tool, the necessary vertical, angular feed movement.

Tool head & its detail's:-

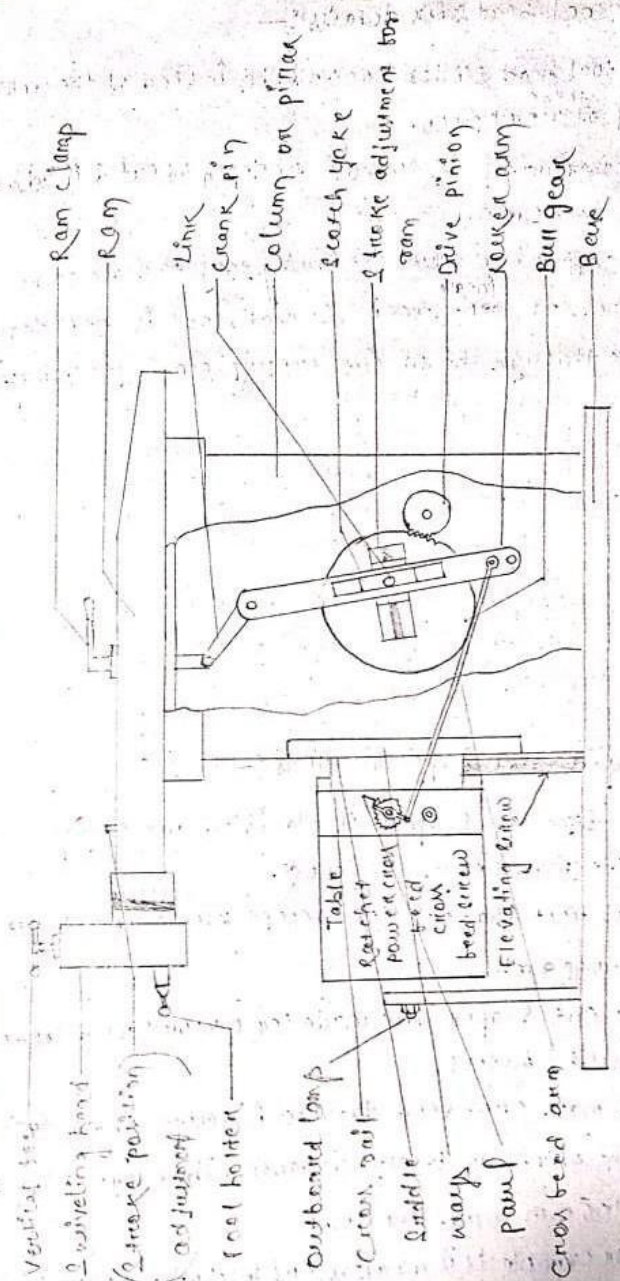

The tool head & fix details :-

- The tool head slides controls the in feed of the cutting tool ^{into the} workpiece.
- In other words it controls the depth of cut & is adjusted by a lead screw.
- The clapper box allows the cutting tool to leave on the return on ^{ideal} stroke, so that the tool is not dragged back through the uncut workpiece & get damage.

Shaper size & specifications :-

- The size of shaper is classified according to the max. length of stroke.
- Push-cut shapers can accept work sizes from 100 to 900 mm.
- Pull-cut shaper are made for ϕ work requirements upto 1.2 m length.
- The max. cross feed distance is generally equivalent to the max. ram stroke distance. Therefore a shaper of 400 mm max. stroke. for example it is capable of machining a part with

a plane surface that measures at least 400 mm square

Specification of a shaper :-

Max. ram stroke 700 mm

max. tool overhang 200 mm

Distance bet. table surface & tool
Max: 100 mm
Min: 80 mm

Dimension of table working surface 700 mm x 150 mm

Max. travelled to table
Horizontal 700 mm
Vertical 320 mm

Horizontal feed for double stroke 0.25 to 5 mm

principle movement motor power 7 kW

Overall dimension 2185 mm x 1750 x 1780 mm

2020/4/3 23:30

Shaper drive mechanism :-

- A shaper drive mechanism changes the rotary motion of the power source into the reciprocating motion of the ram.
- Metal cutting is carried out during the forward stroke of the ram, the return stroke of the ram does no cutting & hence is called ideal stroke.
- Since, return stroke does no cutting, the drive system incorporate a quick return mechanism so that the ram moves faster during return stroke in order to minimize the ideal time.
- Some of the shaper drive mechanism
 - a. Slotted link quick return mechanism
 - b. Whitworth's quick return mechanism
 - c. Hydraulic mechanism
- a. Slotted link quick return mechanism :-

- Slotted link mechanism is very common in mechanical shaper.
- The mechanism is simple & compact.
- It converts the rotary motion of the electric motor & gear box into the reciprocating motion of the ram.
- The slotted link mechanism gives the ram a higher velocity during the return non-cutting stroke than its forward cutting stroke thereby reducing the time wasted during the return stroke.
- The Bull gear is driven by a pinion which is connected to a motor shaft through a gear box with 7, 8 or more speed available.
- The Bull wheel has a slot, the crank pin 'A' is secured into the slot, at the same time it can slide in the slotted crank 'B'.
- When the bull wheel rotate, the crank pin 'A' also rotates & slide through the slot in the slotted crank 'B'.
- This makes the slotted crank to oscillate about its one end 'c'. This oscillating motion of slotted crank (through the link 'D') makes the ram to reciprocate.
- The intermediate link 'D' is necessary to accommodate the size & bar of the crank.
- The position of the crank pin 'A' in the slot in the bull wheel decides the length of the stroke of the shaper, but here it is away from the centre of

Bull wheel, the longer is the stroke.

→ The cutting stroke of the dam is completed while the crank pin moves A to A_1 & the slotted link goes from left to right. Similarly the return stroke of the crank pin move from A_1 to A & the slotted link changes its position from right to left.

→ The time taken by the ideal & cutting stroke of the dam is proportional to the angle $\angle AZA_1$ & $\angle A_1ZA$ respectively.

→ Since the crank pin 'A' moves at a constant uniform velocity & is smaller, it is obvious that the ideal return stroke is quicker than the forward cutting stroke & hence the slotted link mechanism is known as "quick return mechanism."

* MILLING MACHINES *

Q.1 → How the milling machines are classified and illustrate them accordingly?

Ans:- The usual classification according to the general design of the milling machines are:-

1. Column and knee type:-

- (a) Hand milling Machine
- (b) Plain milling Machine.
- (c) Universal milling Machine.
- (d) Omniversal milling Machine.
- (e) Vertical milling Machine.

2. Manufacturing of fixed bed type

- (a) Simple milling Machine.
- (b) Duplex milling Machine.
- (c) Triplex milling Machine.

3. Planer Type.

4. Special Type

- (a) Rotary table milling Machine.
- (b) Drum milling Machine.
- (c) Planetary milling Machine
- (d) Pantograph, profiling and traced controlled milling Machine.

① Column and knee Type:-
For general shop work the most commonly used is the column and knee type where the table is mounted on the knee casting which is turn is mounted on the vertical slides of the main column. The knee is vertically adjustable on the column so that the table can be moved up and down to accommodate work of various heights.

The column and knee type milling machines are classified according to the various methods of supplying power to the table, different movements of the table and different axis of rotation of the main spindle.

(a) Hand Milling Machine:-

The simplest of all types of milling machine is the hand miller in which the feeding movement of the table is supplied by hand control. The cutter is mounted on a horizontal arbor and is rotated by power. The machine is relatively smaller in size than that of other types and is particularly suitable for light and simple milling operations such as machining bolts grooves and key ways.

(b) Plain milling Machine:-

The plain milling machines are much more rigid and sturdy than hand millers for accommodating heavy workpiece. The milling machines table may be fed by hand or power against a rotating cutter mounted on a horizontal arbor. A plain milling machine, having horizontal spindle, is also called horizontal spindle milling machine. In a plain milling machine the table may be fed in a longitudinal cross or vertical directions. The feed is longitudinal when the table is moved at a right angle to the spindle, it is cross when the table is moved parallel to spindle, and the feed is vertical when the table is adjusted in the vertical plane.

(c) Omniversal Milling Machine:-

In this machine the table besides having all the movements of a universal milling machine, can be tilted in a vertical plane by providing a special arrangement at the knee. Also the entire knee assembly is mounted in such a way that

it may be fed in longitudinal direction horizontally. The additional servival arrangement of the table enables in to machine taper spiral grooves and in worm, bevel gears etc. It is essentially a tool room and experimental shop machine.

(1) Vertical milling machine:-

A vertical mill machine can be distinguished from the horizontal milling machine by the position of its spindle which is vertical or perpendicular to the work table. The machine may be of plain or universal type and has all the movements of the table for proper setting and bedding the work. The spindle which is clamped to the vertical column may be swivelled at an angle permitting the milling cutter mounted on the spindle to work on angular surfaces. In some machine, the spindle can also be adjusted up and down relative to the work. The machine is adopted for machining grooves, slots and flat surfaces. The end mills and face milling cutters are the usual tool mounted on the spindle.

1. Base
2. Saddle.
3. Table
4. Spindle head
5. Column.

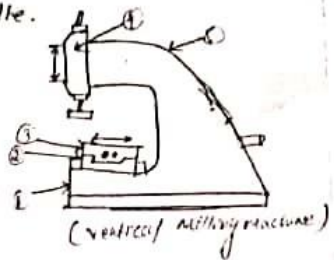

(2) Universal milling machine:-

It is most versatile of all the milling machines, and often rather it is the most useful machine tool as it is capable of performing most of the machining operations. With its application the use of larger number of other machined tools can be avoided. It differs from the plain milling machine only in that the table can be given one more additional movement. Its table can be swivelled on the saddle on the horizontal plane. For this, circular guideways are provided on the saddle along which it can be swivelled. A graduated circular base is incorporated under the table, with a datum mark on the saddle, to readily directly the angle through which the table has been swivelled. The special feature enable the work should be set an angle with the cutter for milling helical and spiral flutes and grooves. Its over arm can be pulled back or removed and a vertical milling head can be fitted on a place of the another to use it as a vertical milling machine.

(3) Manufacturing or fixed bed type:-

The fixed bed type milling machines are comparatively large, heavy and rigid and differ radically from column and knee type milling machines by the construction of its table mounting. The table is mounted directly on the ways of fixed bed. The table movement is restricted to reciprocation at right angles to the spindle axis with no

provision for cross or vertical adjustment. The cutter mounted on the spindle heads respectively on a duplex machine, the spindle heads respectively are arranged one on each side of the table. In tripex type the third spindle is mounted across rail. The usual feature of these machines is the automatic cycle of operation for feeding the table, that is repeated in the regular sequence. The feed cycle of the table includes the following start, rapid approach, slow feed for cutting, rapid traverse to next workpiece, quick return and stop. This automatic control of the machine enables it to be used with advantage in repetitive type of work.

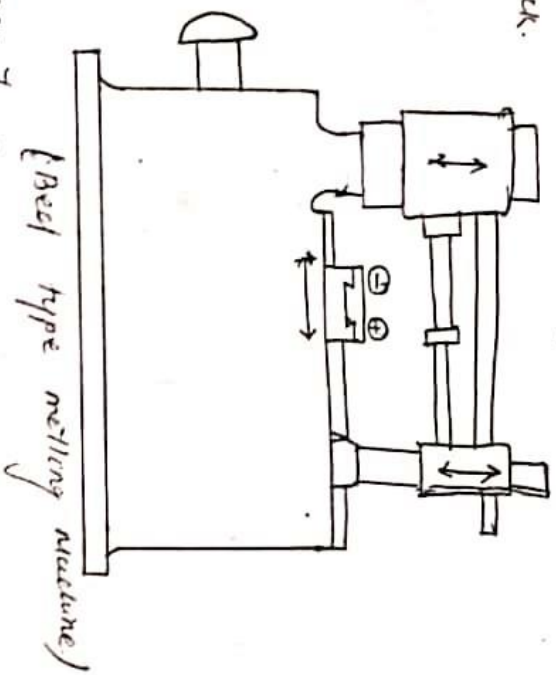

3) Planner Type:- It is also called plano-miller milling machine. The plano miller, is a machine built up for heavy duty work, having spindle heads adjustable in vertical in traverse direction. It resembles a planner and like a planner

machine, it has across rail capable of being raised or lowered carrying the cutter their heads and the scales, all supported by rigid uprights. There may be number of independent spindles carrying cutter on the rail as well as two heads on the upright. This arrangement of multiple cutter spindles enables number of work surfaces to be machined simultaneously. There by obtaining

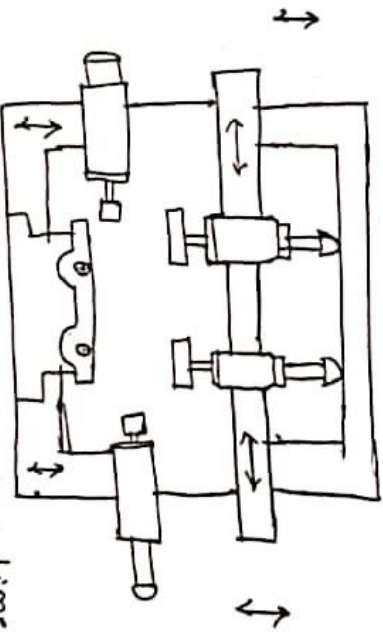

great reduction in production time. The essential difference betⁿ a planer and plano-miller is in the table movement. In a planer, the table moves to give the cutting speed, but in a plano-milling machine the table movements gives the feed. Hence the table movement in a plano-milling machine is much slower than that of a planning machine. Non-drive spindles are provided with higher power driven spindles are powered to the extent of 100 h.p. and the rate of metal removal is tremendous. The use of the machine is limited to production work only and is considered ultimate in metal removing capacity.

4) Special Type:- Milling machines of non-

Special designs have been developed to suit special purpose. The features that they have in common are the spindle for rotating the cutter and provision for moving the tool or the work in different directions. The following special type of type machines of interest are described below:-

(a) Rotary table Machine:-

The construction of the machine is a modification to a vertical milling machine and is adopted for machining flat surfaces at production rate. The base milling cutters are mounted on two or more vertical machine spindles and a number of work pieces are clamped on the horizontal surface of a circular table which rotate about a vertical axis. The cutters may be set different height relative to the work so that when one of the cutter is roughing the pieces, the other is finishing them.

(b) Drum milling machine:-

The drum milling machine is similar to a rotary table milling machine is that it's work supporting table, which is called a drum, rotates on a horizontal axis. The base milling cutters mounted on three or four spindle heads rotate in horizontal axis and remove metal from workpiece presented on both the face of the drum. The

finished machined parts are removed after one complete turn of the drum, and then the new ones are clamped to it.

(c) Planetary milling machine:-

In a planetary milling machine, the work is held stationary while the revolving cutters or cutter move in a planetary path to finish a cylindrical surface on the work either on a internally or externally or simultaneously. The machine is particularly adopted for milling internal or external threads of different pitches.

(d) Pantograph milling machine

A pantograph machine can duplicate a job by using a pantograph mechanism which permits the size of the workpiece reproduced to be smaller than, equal to or greater than the size of a template or model used for the purpose. A pantograph is a mechanism that is generally constructed of four bars or links which are joined in the form of a parallelogram. Pantograph machines are available in two dimensional or three dimensional models. Two dimensional pantograph is used for engraving letters or other designs, where as three dimensional models are employed for copying and shape and contour of the workpiece.

(e) Milling machine:- A pantograph machine duplicates the full size of the template attached to the

machine. This is practically a vertical milling machine of bed type in which, the spindle can be adjusted vertically on the cutter head horizontally across the table. The movement of cutter is regulated by a hardened guide pin. The pin is held against and follows the outline or profile of a template mounted on the table at the side of the job. The longitudinal movement of the table and crosswise movement of the cutter head follow the movements of the guide pin on the template.

(b) Tracer controlled milling machine:—

The tracer controlled milling machine reproduces irregular or complex shapes of dies, moulds etc. by synchronized movements of the cutter and tracing element. The feeding motion of the machine is controlled automatically by means of a stylus that scans a profiled or a contoured model which is to be produced. The movement of the stylus energizes an oil relay system which in turn operates the main hydraulic system of the table. The arrangement is termed as servomechanism.

Q.2 → Explain the procedure of simple indexing?

Ans:— This method of indexing is used when the direct method of indexing can not be employed for obtaining the required no. of divisions on the work. For example, if the work is required

to be divided into 22 equal divisions the direct indexing can not be used, because 22 is not divisible to any of the hole circles on the direct or indexing plate. For such cases, simple indexing can easily be used.

For this, either a plain indexing head or a universal dividing head can be used. This method of indexing involves the use of the crank, worm, worm wheel and index plate. As already described, the worm wheel carries 40 teeth and the worm is single start. The worm wheel is directly mounted on the spindle.

When the crank pin is pulled outwards and work is rotated, the worm will rotate which in turn, will rotate the worm wheel and the spindle and the work, since the worm has single start thread and the worm wheel has 40 teeth, with one turn of the crank the worm wheel rotates through one pitch distance, i.e. equal to $\frac{1}{40}$ of a revolution. Similarly two turns of crank will make the work to rotate through $\frac{2}{40}$ and 3 turns through $\frac{3}{40}$ of a revolution. Thus, the crank will be to be rotate through 40 turns in order to rotate the work through one complete turn. The holes on the index plate serve to subdivide the rotation of the index crank.

Now we want to divide the work into number of divisions, the corresponding crank movements will be as given below; for two divisions on the work, the crank will make

$$\frac{40}{2} = 20 \text{ turns of each division}$$

For 4 division on the work, the crank will make $\frac{40}{4} = 10$ turns.

For 10 divisions on the work, the crank will make $\frac{40}{10} = 4$ turns.

Similarly for 'n' divisions on the work the crank will make $\frac{40}{n}$ turns.

Let us consider that the work has to be divided into 23 equal divisions, then the corresponding crank movements will be given by;

$$\text{Crank movements} = \frac{40}{23} = 1\frac{17}{23} \text{ turns.}$$

Now, on the obtained result, the whole number indicates the number of full turns the crank has to move through, and the fraction represents the part of the turn that the crank has to make, in addition to the above, in order to make the work to rotate through one required division i.e., $\frac{17}{23}$ of a revolution. In the fraction, the numerator the no of holes on the circle to be used. Thus for the above indexing for each division on the job, the crank will make, one complete revolution and will move further through

17 holes on 23 holes circle.

To set the spacing on the indexing plate, and avoid error and confusion in counting the hole everytime, the sector arm should be used. These arm can be set such that they will contain betⁿ them only as many holes on a particular circles as are required. This spacing can be maintained for as many operations as desired. For giving full turn the crank, the pin can be withdrawn from the hole and the crank turned. For the remained, should be moved from one arm to the other and then engaged. After engaging the pin the arms can be moved further to ^{set} the spacing for the next operation.

Example:-

It is required to divide to periphery of a job into 60 equal divisions. Find the crank movement?

Solution:-

$$\text{Required movement} = \frac{40}{60} = \frac{2}{3}$$

selecting 15 holes circle on plate no: 1, we get

$$\frac{2}{3} = \frac{2}{3} \times \frac{6}{6} = \frac{12}{18}$$

i.e. 12 holes on 18 hole circle Ans.

Q.9:- Explain the procedure for compound

Indexing?

Ans:- This method of indexing is employed when the number of divisions required is out side the range that can be obtained

by simple indexing, involves the use of to separate simple indexing movements and is performed in two stages:-

- (1) By turning the crank a definite amount in one direction in the same way as in simple indexing.
- (2) By turning the indexing plate and the crank both, either in the same or reverse direction, thus adding further movement to or subtracting from that obtained in the first stage.

Procedure:-

In order to obtain the required no of divisions through compound indexing proceed as follows:-

- (i) Factorise the no of divisions required
- (ii) Factorise the standard no 40.
- (iii) select two of any two circles on the same plate and on its same side. Factorise their difference.
- (iv) Factorise the no of holes of one circle.
- (v) Factorise the no of holes of the other circle.

After obtaining these factors place them as follows:-

Factors are divisions required \times factors of distance of hole circles.

First check:-

If suitable index circles have been selected then all the factors in the numerator will be cancelled by those in the denominator. That is you will get unity in the numerator. It does not happen, select another set of circles and make another attempt in the same way as above. Repeat it till you get 1 in the numerator.

Now, suppose the above expression, after simplification, comes to the form $\frac{k}{a}$, where k may be any number. If a and b denote the number of the holes on the two circles, then the required indexing movement will be given by:-

$$\frac{k}{a} - \frac{k}{b} \text{ or } \frac{k}{b} - \frac{k}{a}$$

The positive part of the indicates the movement of the crank in one direction and the negative part denotes the movement of the plate in crank in the positive direction. It is always advisable to keep the backward motion as smaller of the two.

And Check:-

After finding the above two expressions, check that the algebraic sum of the two movements, i.e. of the crank in one direction and that of the plate and crank in the opposite direction should be equal to $40/N$. where 'N' is no of divisions required. or we can say that, if the correct result is obtained, then:- $\frac{k}{a} + \frac{k}{b} = \frac{N}{H}$

Example - 0: - Compound indexing for 87 divisions.

Solution: -

Suppose we select circles of 29 and 33 holes. putting the relative factors in the form of the above stated expression and applying the first check we get: -

$$\frac{3 \times 29 \times 22}{27 \times 27 \times 25 \times 29 \times 33} = \frac{1}{110}$$

i.e. we get - unity in the numerator, indicating that the circles, selected are correct. therefore, the required indexing movement is given by.

$$\frac{110}{29} - \frac{110}{33} = 3 \frac{23}{29} - 3 \frac{11}{33} \quad \dots (i)$$

$$\text{or } \frac{110}{33} - \frac{110}{29} = 3 \frac{11}{33} - 3 \frac{23}{29} \quad \dots (ii)$$

Since there are three common complete turn in each case they cancel out, leaving the required movement as: -

$$\frac{23}{29} - \frac{11}{33} \quad \text{or} \quad \frac{11}{33} - \frac{23}{29}$$

Since we keep the forward motion of crank as ~~stronger~~ then the backward motion of the plate and crank path, we adopt the first expression for the required indexing movement.

i.e. the movement = $\frac{23}{29} - \frac{11}{33}$

Or, in more elaborate terms, we can say that the work will be indexed through $1/87$ of a revolution each time as the crank is moved forward 23 holes on 29 hole circles and the plate and crank backward 11 holes on 33 hole circles.

Now applying the second check,

$$\frac{23}{29} - \frac{11}{33} \quad \text{or} \quad \frac{40}{87} - \frac{40}{N}$$

i.e. the algebraic sum of the two movements obtained is equal to $40/N$, confirming that the movements obtained are correct.



GRINDING

Q.1. - Define Grinding?

Grinding is a process of removing material by the abrasive action of a revolving wheel on the surface of a work piece, in order to bring it to the required shape and size. So far as the cutting action is concerned, grinding is very much similar to other machining operation since the microscopic examination of the removed material reveals that the same is in the form of small chips, similar to those obtained in other machining operations. The wheel used for performing the grinding operation is known as 'Grinding wheel'. It consists of sharp crystals, called abrasives, held together by a bonding material or bond. The wheel may be single piece or solid type or may be composed of several segments of a abrasive block joined together. In most cases, it is a finishing operation and a very small amount of

material is removed from the surface during the operation.

Q.2. - Explain the manufacturing of grinding wheel

Ans. - Mainly these wheels are made in many ways. Essentially they consist of a number of bonded abrasive blocks, held together by suitable means. A typical example of these will consist of a these blocks fastened to a metal wheel by a chuck. Spacers are always provided between the blocks. It is mainly employed on vertical spindles grinders with reciprocating or rotary ~~table~~ table. They are mainly used in surface grinding and carrying the following main advantages:-

- (i) It is easier to manufacture these wheels in large size in comparison to the solid wheels of same size.
- (ii) They cut intermittently, and hence cool grinding is the result. A segmental grinding wheel is shown in the next page fig.

There is a special variety of grinding wheels which possess 'core and plug' shapes. They are employed to grind

concrete shapes to which their outer surfaces suit.



(A segmented grinding wheel)

They carry threaded bushing on the mounting side as shown in down fig. This figure shows the standard

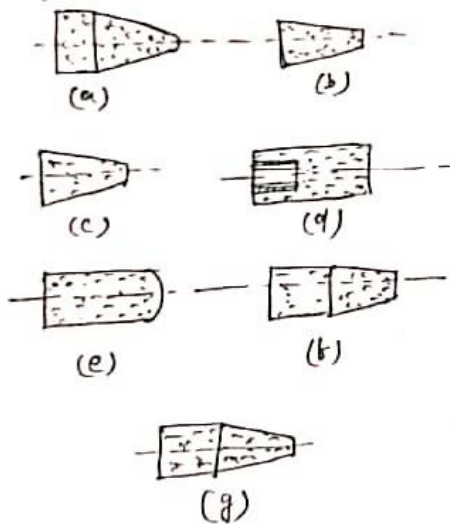

Shapes of 'cone' and 'plug' grinders as per IS : 2324 (part 1) 1985. The detailed drawings are also given in this standard.

An important point to note is that in this type of wheel grinding is performed by all the surfaces except the flat surface on the mounting side.

Q.3:- State criteria for selection of grinding wheels?

Ans:- Selection of a proper grinding wheel is vital necessity to obtain the best results in grinding work. A wheel may be required to perform various different functions like quick removal of stock material, give a high class surface finish, maintain close dimensional tolerances and a single wheel will have to meet all the requirements. It is necessary therefore, that proper grain size, bond, grade, strength, shape and size of wheel should be selected to meet the specific requirements of a job.

In selecting a grinding wheel there are four constant factors and four variables are illustrated below:-

- (1) The material to be ground:- This influence the selection of (a) abrasive (b) grain size (c) grade (d) structure and (e) bond
- (2) Aluminum oxide abrasive is recommended for materials of high tensile strength and silicon carbide for low tensile strength.

- (c) Fine grain is used for hard and brittle materials and coarse grain for soft ductile metals.
- (d) Fine grain is used for hard and brittle materials and coarse grain for soft ductile materials.

(e) Hard steel is used for soft materials and soft wheel for hard materials.

(2) Amount of stock to be removed:-
This involves accuracy and finish. Coarse grain is used for fast cutting and fine grain for fine finish wide spacing for rapid removal and close for fine finish, resinoid, rubber and shellac bond for high finish.

(3) Area of contact:-
Area of contact influences the selection of (a) grit size (b) grade and (c) structure number.

Fine grain and close grain spacing are useful where other area of contact involved is small, and coarse grain and spacing are employed where a large area of contact is concerned.

(4) Type of Grinding Machine:-
Type of grinding machine determines to

rigidly constructed machines take softer wheel than the lighter more flexible types. The combination of speeds and bonds on sound precision machines may be offset the grade of wheel describe for best results.

(i) wheel speed:-
The wheel speed influences the selection of grade and bond. The higher the wheel speed with relation to work speed, the softer the wheel should be. Vitrified bond is usually specified for speeds up to 2000 s.m.p.m (or 6500 s.m. or p.m) and the rubber, shellac or resinoid bonds for speed over 2000 s.m.p.m (or 6500 s.p.p.m).

(ii) work speed:-
The work speed with relation to wheel speed determines the hardness of the wheel. The higher the work speed with relation to the wheel speed, the harder the wheel should be. Variable work speed are often provided on grinding machines to preserve the proper relative surface speeds between the work and wheel as the wheel diameter decreases because of wear.

(iii) Condition of grinding machine:-
The condition of grinding machine

wheel to be selected. Spindle coarse in their bearings, and in case or shury foundations would necessitate the use of harder wheels then would be the cost of the machine wear in better operating conditions.

(iv) Personal factor:-

The skill of workman is another variable factor which should be considered in selecting the wheel, as for instance on the grinding cost considerably on the same work in the same factory.

Q.9:- Explain the working principle of cylindrical grinders?

Ans:- The principle of cylindrical grinding involves holding the workpiece rigidly on centres, in a chuck or in a suitable holding fixture, rotating it about its axis and bedding a fast revolving grinding wheel against the same. If the work surface to be ground is longer than the face width of the grinding wheel, the work is traversed past the wheel as the wheel past

is done either by hydraulic or mechanical power or by hand. The feed is given to the work or the wheel at the end of each traversing moment. In case the width of wheel face is more or equal to the length of the work surface to be ground, the wheel may be fed in which no traversing movement of it or that of the work. This is known as plung grinding.

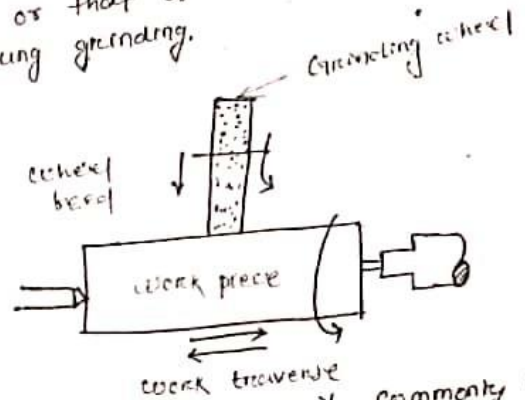

The simplest and quite commonly used type of cylindrical grinder is a tool post grinder used on lathe. When wheels of large diameter are used, they can be mounted directly on the motor shaft. For mounting small wheels on auxiliary shaft is provided, which run at a relatively much higher speed than the motor. Both external and internal diameter cylindrical grinding can be done on lathe by this equipment.

Cylindrical grinding machines are mainly of the following three types:-

1. Plain cylinder grinders
2. Universal cylinder grinder.

3. centerless grinder

Plain cylindrical spindles:-

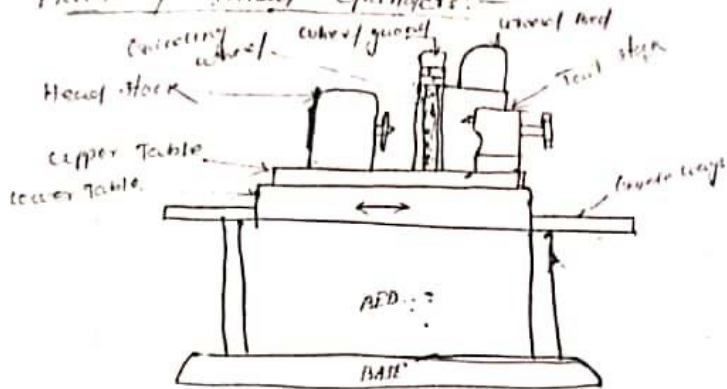

In this case the workpiece is usually held betⁿ two centers. One of these centers is in the headstock and other in the tail stock. In operation, the rotating work is traversed across the face of the rotating grinding wheel. At the end of each traverse, the wheel is fed into the work by amount α to the depth of cut. While mounting the work betⁿ centers, the headstock center is not disturbed. It is the tail stock center which moved in or out, mainly or hydraulically, to inset and hold the work. Tail stock and head stock both can be moved along the table to suit the work. Table is usually made in two parts. The upper table carries the tail stock,

head stock and workpiece and can be swivelled on a horizontal plane, to maximum of 10° on the side, along the circular ways provided on the lower table. This enable grinding of taper surfaces. The lower table is mounted on a horizontal guide ways to provide longitudinal traverse to the upper table and hence the work. The table movements can be both by hand as well as power. Hydraulic table drives are usually preferred.

Q.5:- with the help of a neat diagram, explain the construction and working of a centerless grinder.

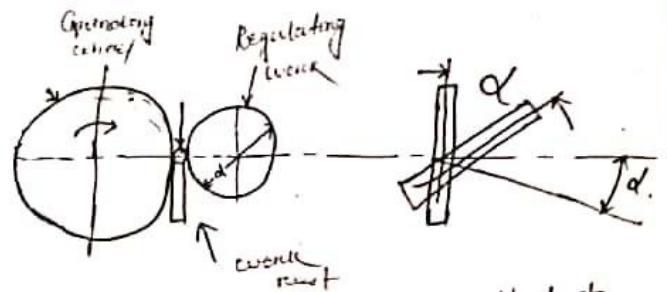

Centerless grinding is a method of grinding exterior cylindrical, tapered and form surfaces on workpieces that are not held and rotated on centers. The principal elements of a external centerless

grinder are the grinding wheel, regulating wheel, and the work rest. Both wheels are rotated in same direction. The work rest is located between the wheels. The work is placed on the workrest, and the latter, together with the regulating wheel, is fed forward, forcing the work against the grinding wheel.

The axial movement of the work past the grinding wheel is obtained by tilting the regulating wheel at a slight angle horizontal. An angular adjustment of 0 to 8 or 10 degrees is provided in the machine for this purpose. The actual feeds (s) can be calculated by the formula.

$$s = \frac{2\pi r n \sin \alpha}{60}$$

where s = Feed in mm per minute.

n = Revolution per minute

r = dia of regulating wheel (in mm)

α = angle of inclination of wheel.

centerless grinding may be done on one of

the three ways;

(a) Through feed:-
In through feed grinding, the work is passed completely through the space between the grinding wheel and regulating wheel, usually with guides at both ends. This method is used when there are no shoulders or other forms to interfere with the passage of the work. It is useful for grinding long, slender shafts or bars.

(b) Infeed:-
In infeed grinding which is similar to plunge grinding or form grinding, the regulating wheel is drawn back so that work piece may be placed on the work rest blade. Then it is moved into feed the work against the grinding wheel. This method is useful to grind shoulders, and formed surfaces.

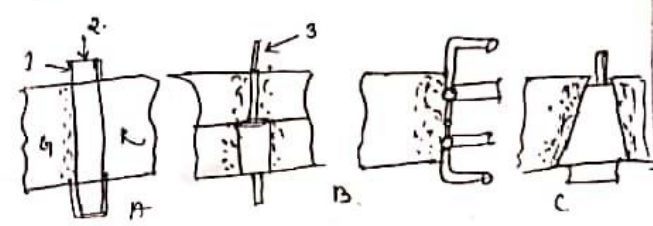

(c) End feed:-
In end feed grindings, used to produce taper, either the grinding wheel

or regulating wheel or both are formed to a taper. The work is fed lengthwise betⁿ the wheels and is ground as it advances until it reaches the end stop.

The advantage of centerless grinding are:-

- (i) The process is continuous and adapted for production work.
- (ii) The size of the work is ~~easy~~ easily controlled.
- (iii) A low order of skill is needed in the operation of the machine.
- (iv) As the blocking condition exists during the grinding process, less metal to be removed.

Some disadvantages are:-

- (i) Work having multiple diameter is not easily handled.
- (ii) In hollow work there is no certainty that the outside diameter will be concentric with the inside diameter will be concentric with the inside diameter.

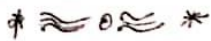

SURFACE FINISH, LAPPING

Q.1 with the help of net diagram, describe the process of surface finishing?

Ans:- Superfinishing is more or less like a lapping process with a speed difference that the abrasive used is a bonded abrasive. The abrasive are used in a particular way under controlled conditions to produce a high quality surface finish on the work surface. It should be particularly noted that it is not essentially a metal removing operation and it is necessary therefore that in order to have reciprocal rate of production, all the components to be superfinished should first be finished through other operations, very nearly to the final size. In order to bring the work to such a close dimensional accuracy, grinding is usually employed prior to superfinishing.

Principle of operation:-

The principle of superfinishing is shown schematically in fig (1). One face of the abrasive block is given the shape

of the surface to be superfinished. This block is held in suitable holder or grill and placed on the work surface.

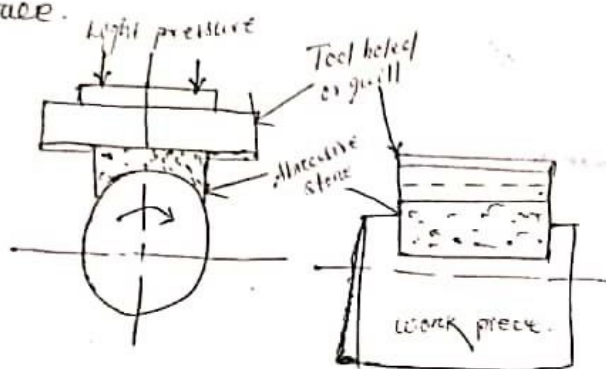

(Principle of superfinishing operation)

The quill is spring loaded to provide a light pressure on the work surface. The workpiece is rotated at a very slow surface speed of the order of 2 to 20 m/min. As the work rotates the abrasive block reciprocates forward and backward at a rapid rate. In order to cover the entire length of the workpiece, the block overruns by a amount 1.5 mm to 6 mm

on both end of its stock. A suitable lubricant is used in this process. An oscillatory motion obtained due to the combination of rotary motion of the work and reciprocating motion of the abrasive block with rubbing on the stone against the work surface. results in the production of a superfinished surface.

Although this operation can be performed on a small scale on some conventional machine tools like lathe, for performing superfinishing on large scale specially designed and built superfinishing machines are used.

Q.2 What is Lapping? How is done? How many types of Lapping operations are there?

Ans:-

Lapping is an abrading process employed for improving the surface finish by reducing roughness, waviness and other irregularities on the surface. It is used on both heat treated and non-heat treated metal parts. It should, however, be noted

that where good appearance of the job surface is the only requirement, it should not be employed, since there are other finishing methods which will give the same desired result with low cost. It should be used only where accuracy is a vital consideration in addition to the surface finish. The basic purpose of lapping is to minimise the extremely minute irregularities on the job surface after some machining operation. In brief, we can say that lapping is basically employed for removing minor surface imperfections, obtaining geometrically true surface, obtaining better dimensional accuracy and, thus facilitate, a very close fit between two contacting surfaces.

The material to be selected for lapping tool or lap largely

depends upon the individual choice and the availability and no specific rule can be laid for the same. The only consideration that has to be made is that the material should be soft for making a lap so that the abrasive grains can be easily embedded in its surface. The commonly used materials are soft iron, copper, brass lead and sometimes hard wood.

Lapping operations are broadly classified into the following two main groups.

1. Equalising Lapping
2. Form Lapping.

① Equalising lapping:-

It is the operation of running two similar parts or shapes together with an abrasive between them when two such surfaces are together in constant contact with the abrasive, their surface finish is improved and any →

deviation of shape corrected. Those results can be easily seen during seating of tapered valves on their seats or when gears are rotated together with these objectives.

Form Lapping:-

As is clear from the name itself, it is not merely rubbing of surfaces together but it is the shape of the lap that is responsible for finishing a corresponding work surface. Obviously the lap is used in the operation will be a form lap i.e., conforming the shape to be lapped.



SLOTTER

Q.1 What is slotting machine and how they are classified?

A slotting machine or slotter has its own importance but a few particular classes of work. Its main use is in cutting different types of slots. Its other uses are in machining irregular shapes, circular surface etc.

The slotting machine falls under the category of reciprocating type of machine tools similar to a shaper or planner. It operates almost on the same principle as that of a shaper. The major difference betⁿ a slotter and shaper is that in a slotter the ram holding the tool reciprocates in a vertical axis, where as in a shaper the ram holding the tool reciprocates in a horizontal axis. A vertical shaper and a slotter are almost similar to each other as regard to their construction operation and use.

The slotter is used for cutt^g.

ing grooves, key ways and slots of various shapes, for handling large and awkward workpieces, for cutting internal and external gears and many other operations which can't be conveniently machined in any other machine tools describe the before the slotting machine was developed by Brunel in the year 1800 much earlier than a shaper was invented.

There are mainly two classes of slotter:—

1. Puncher slotter.
2. Precision slotter.

(i) Puncher slotter:—

The puncher slotter is a heavy, rigid machine designed for removal of large amount of metal from large forgings or castings the length of a puncher slotter is substantially large. as max. length is 1800 to 2000 mm.

The puncher slotter room is usually driven by a spiral pinion mechanism with the rack teeth cut on the under side of the room. The pinion is driven by available speed reversible electric motor similar to that of a planer the bed is also controlled by electric gears.

(ii) precision slotter:—

The precision slotter is a lighter machine and is operated at a high speed. The machine is designed to take light cuts giving accurate finish. Using special jigs, the machine can handle a number of identical works on a production basis the precision machines are also used for general purpose work and usually fitted with whitworth quick return mechanism.

Q.3 → what are the different parts of a slotting machine. Describe about the main parts of machine:

1. Base
2. Column
3. Saddle
4. Cross-Slide.

5. Rotating table

6. Ram and tool head assembly

7. Ram drive mechanism

8. Feed mechanism.

The main parts of a slotting machine are:-

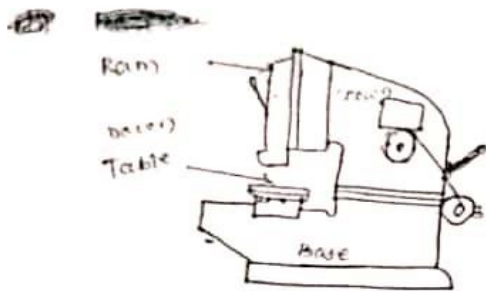

(1) Base:-

It is a heavy cast-iron construction and is also known as 'bed'. It acts as a support for the column, the driving mechanism ram, table and other fittings. At its top it carries horizontal ways, along which the table can be traversed.

(2) Column:-

It is another heavy cast-iron body

which acts as a housing for the complete driving mechanism. At its front it carries vertical ways, along which the ram moves up and down.

(3) Table:-

Usually a circular table is provided on slotting machine. In some heavy duty slotters, either a rectangular or circular tables can be mounted. On the top of the table are provided T-slots to clamp the work or facilitate the use of fixtures, etc.

(4) Ram:-

It moves a vertical direction between the vertical guide ways provided with front of the column. At its bottom, it carries the tool post on which the tool is held. The cutting action takes place during the downward movement of the ram.

Q-3 → What are the operations performed by the slotting machine?

Ans:- The operations performed by the

Slotting machine work:-

- (i) Machining Flat surface
- (ii) Machining cylindrical surface
- (iii) Machining irregular surface.
- (iv) Machining slots, keyways and grooves.

(1) Machining Flat surface:-

The external and internal ~~flat~~ surface may be generated on a workpiece easily in a slotting machine. The work to be machined is supported on a parallel clips so that the tool will have clearance with the table when it is at the extreme downward position of the stroke. The work is then clamped properly on the table and the position and the length of stroke is adjusted. A clearance of 20 to 25 mm. is left before the beginning of cutting stroke, so that the first movement may take place

during this idle part of the stroke. The table is clamped to prevent any longitudinal or rotary travel and the cut is started from one end of work. The cross feed is supplied at the beginning of the each cutting stroke & the work is completed by using a rough and finishing tool. While machining an external surface, a hole is drilled in the workpiece through which the slotting tool may pass during the first cutting stroke. A second surface parallel to the first machined surface can be completed without disturbing the setting by simply rotating the table through 180° and adjusting the position of the saddle. A surface perpendicular to the first machined surface may be completed by rotating the table by 90° and adjusting the position of the ~~table saddle~~ or saddle and crosshole.

→
The external and internal surface of a cylinder can also be machined in slotting machine. The work is placed centrally on the rotary table and packing pieces and clamps are used to hold the work securely on the table. The tool is set readily on the work and necessary adjustments of the machine and the machine is started. While machining the feeding is done by the rotary table feed screw which rotates the table through a small arc at the beginning of each cutting stroke.

The work is set on the table and necessary adjustments

of the tool and the machine are made as detailed in other operations. By combining cross, longitudinal and rotary feed movements of the table any contoured surface can be machined on a work piece.

→
Internal and external grooves are cut very conveniently on a slotting machine. A slotter is specially intended for cutting internal grooves which are difficult to produce on other machines. External and internal gear teeth can also be machined in a slotter by cutting equally spaced grooves on the periphery of the work. The indexing or dividing the periphery of the work is done by the graduations on

the rotating table in an
machining grooves or key ways.
Here internal and external groo-
ves are cut very conveniently on
a slotting machine.



* DRILLING *

Q1:- What do you understand by the term 'drill-
ing'? How do you classify different types
of drills?

Ans:- The drilling machine is one of the most
important machine tools in a workshop. As regard its importance it is
second only to the lathe. Although it was
primarily designed to originate a hole, it can
perform a number of similar operations.
In a drilling machine holes may be
drilled quickly and at a low cost. The
hole is generated by the rotating edge of
cutting tool known as the drill which
exerts large force on the work clamp-
ped on the table. As the machine tool
exerts vertical pressure to originate a
hole it is loosely called a drill press.

Drilling machines are manufac-
tured in various sizes and varieties
to suit the different type of work.
They can, however, be broadly classified
as follows:-

- (i) Protable drilling Machine
- (ii) sensitive or bench drill

- (iii) Upright drilling machine (single spindle)
- (iv) Upright drilling machine (Turret Type)
- (v) Radial drilling machine.
- (vi) Multiple spindle drilling machine.
- (vii) Deep hole drilling machine.
- (viii) Boring drilling machine.
- (ix) Horizontal drilling machine.
- (x) Automatic drilling machine.

Q.2 With neat sketch describing the working of bench drilling machine?

Ans:- This type of drilling machine is used for very light work. Its construction is very simple and so at the operation it consists of a cast iron base having a fixed table over it. The vertical column carries a rotating table, the height of which is adjusted vertically along the

column. Also it can be swung to any desired position. At the top of the column is provided the drive, which consists of an endless belt running over two v-pulleys. One of these pulleys is mounted on the motor shaft and other on machine spindle. No gears are used in the drive. Vertical movement to the spindle is given by the lead handle through a rack and pinion arrangement. The spindle usually carries 1 Morse taper. Sensitive drills are normally manufactured having upto 20mm drilling capacity in steel.

The drive mechanism of this machine is illustrated in this fig.

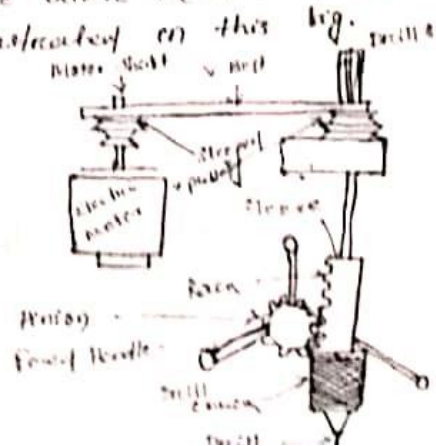

As the motor is switched on. The motor shaft starts revolving and, hence, the V-pulley mounted over it. This, through the V-belt, transmits motion and power to the other V-pulley mounted over the drill spindle. Thus, the spindle starts rotating and therefore the cutting tool (drill). When the drill is required to be fed into the work. It is pressed against the work by means of the feed handle. As the handle is rotated, which is directly mounted on the pinion shaft, the pinion rotates it moves the rack longitudinally and, hence, the spindle and the drill. The key way cut along the spindle facilitates vertical

movements of the spindle while it is rotating under power. Different spindle speeds can be obtained by shifting the V-belt to different pairs of driving and driven pulleys, while the motor continues to rotate on the same speed.

On this machine, the drill rotates at very high speeds so that the required cutting speeds can be obtained on the periphery of small drills used on these machines. The hand feed enables the operator to feed the gradual penetration of the drill into the work material and also since it the drills is cutting properly or have become blunt and needs regrinding. For this reason only it is known as a sensitive drill.

Q.3 →

Explain the working of radial drilling machine? Draw neat sketch necessary?

Ans:-

This machine is very useful because of its wide range of action. Its principle use is in drilling holes on such work which is difficult to be handled frequently. With the use of this machine, the tool is moved to the desired position instead of moving the work to bring the latter in position for drilling.

The machine consists of a heavy, vertical column, round, mounted on large base. The column supports or radial arm which can be raised and lowered to accommodate workpieces at different heights. The arm may

be swung around to any position over the work bed. The drill head containing mechanism for rotating and feeding the drill is mounted on a radial arm and clamped at any desired position. These three movements on a radial drilling machine when combined together permit the drill to be located at any desired point on a large workpiece for drilling the hole.

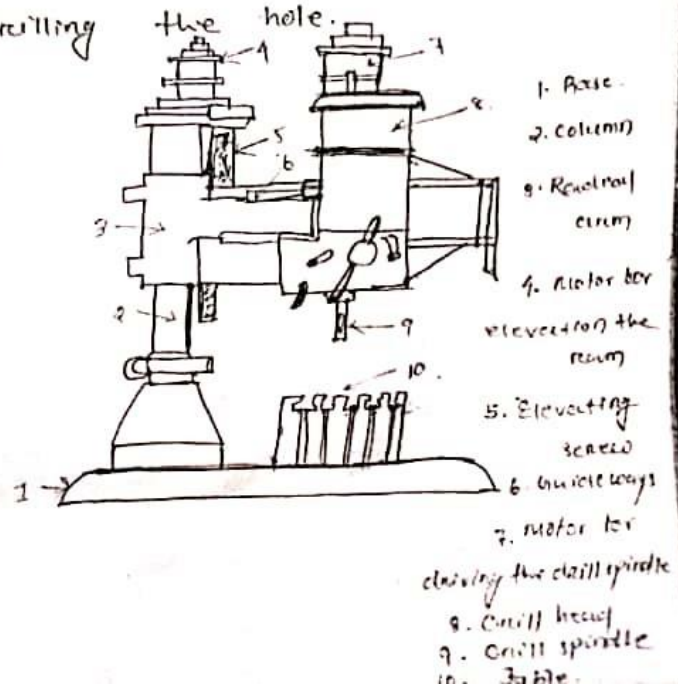

Based on the type and number of movements possible the radial drills can be broadly grouped as:-

Plain radial drilling machine:-

In a plain radial drilling machine provisions are made for vertical adjustment of an arm, horizontal movement of the drill head along the arm, and circular movement of arm in a horizontal plane about the vertical column.

Semi-Universal Machine:-

In a semiconiversal machine, in addition to the above three movements, the drill head can swing about a horizontal axis perpendicular to the arm. This fourth movement of drill head permits drilling hole at an angle to horizontal plane other than the normal position.

Universal Machine:-

In universal machine, in addition to the above four movements, the arm holding the drill head may be rotated on a horizontal axis. All these five movements in a universal machine enables it to drill on a work piece at any angle.